

ELEVATION

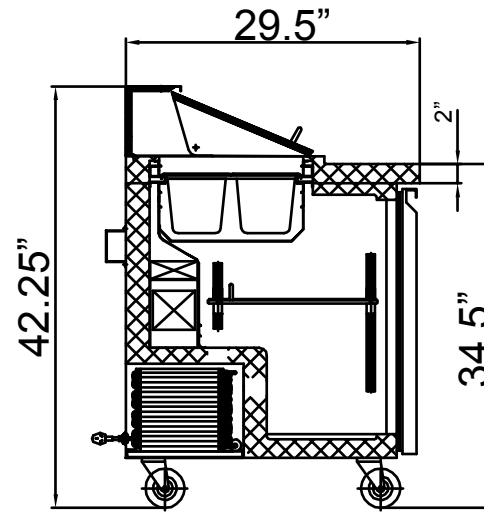

SECTION VIEW

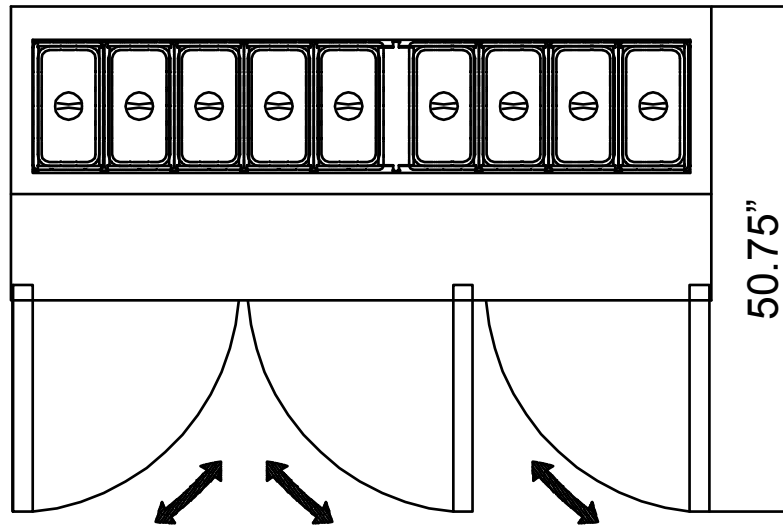

PLAN

SCL3

Model	Compressor:HP	Refrigerant	Thermostat model	Voltage Supply	Capacity	Temperature Range	Exterior Dimensions
SCL3		R134a	Digital Type	110V/60Hz/1PHASE		0°~10°C	70.25" X 29.5" X 42.25"